



GARAGE DOOR OPENER EXTENSION KIT

MODEL: 425-1671

WARNING

- To prevent SERIOUS INJURY or DEATH:
- DO NOT connect power until instructed.
 - CLOSE the door before installation.



www.gdohelp.com
 1-877-GDO-4402
 1-877-436-4402
 2301 Traffic St NE
 Minneapolis, MN 55413

Kit Inventory

	x 1		x 1
	x 1		x 2
	x 1		
	x 1		

Components Required from Opener Inventory

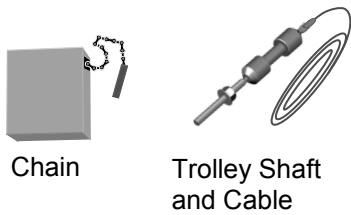

Discard all 5 segments from original opener

-
-
-

STEP 1. To Assemble Rail with "Extended Middle Segment"

Please refer to "Rail and Trolley Assembly" in Owner's Manual.

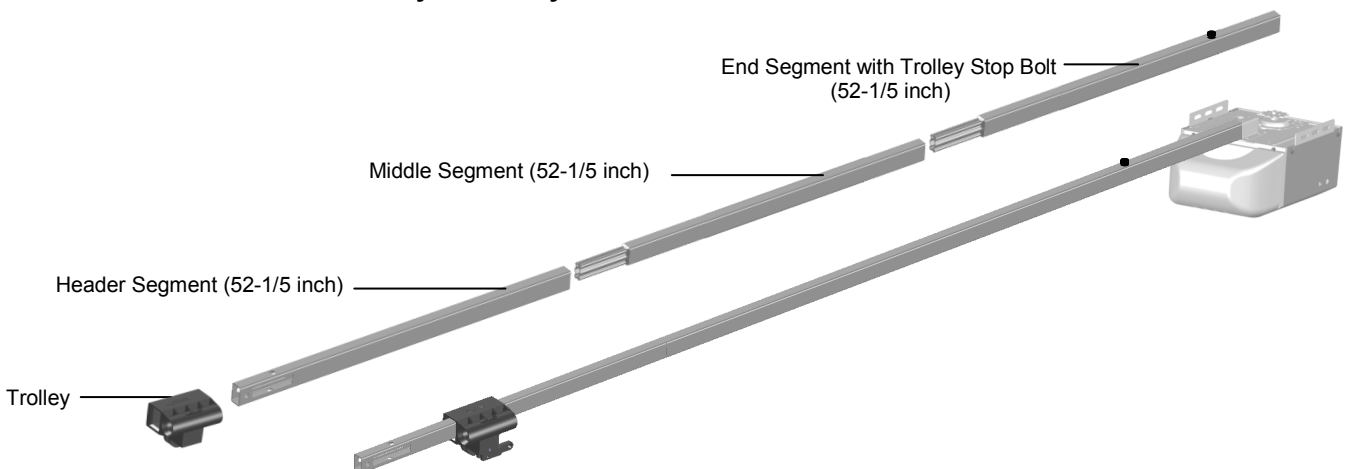

WARNING

- Discard all FIVE of the original rail segment.
- ONLY 3 pieces of extended rail segment should be applied. NEVER connect extra rail segments.
- The opener only services door to max. of 10 FT. height. Door, with other size please call service before installation.

Step 2. Extending the Chain

1. To Disconnect "Chain to Cable Connector" from the Original Chain

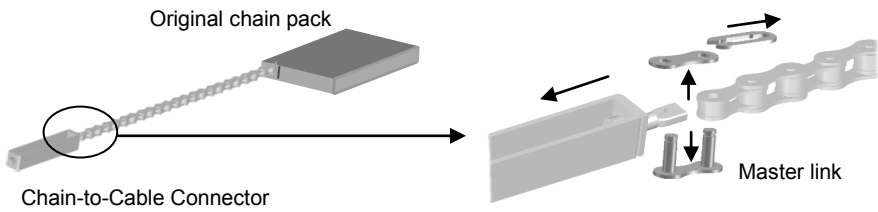

Disconnect the "Chain to Cable Connector" from the original chain by removing the master link.

Keep all the hardware in this step.

2. To Connect "Extended Chain Segment" to Chain

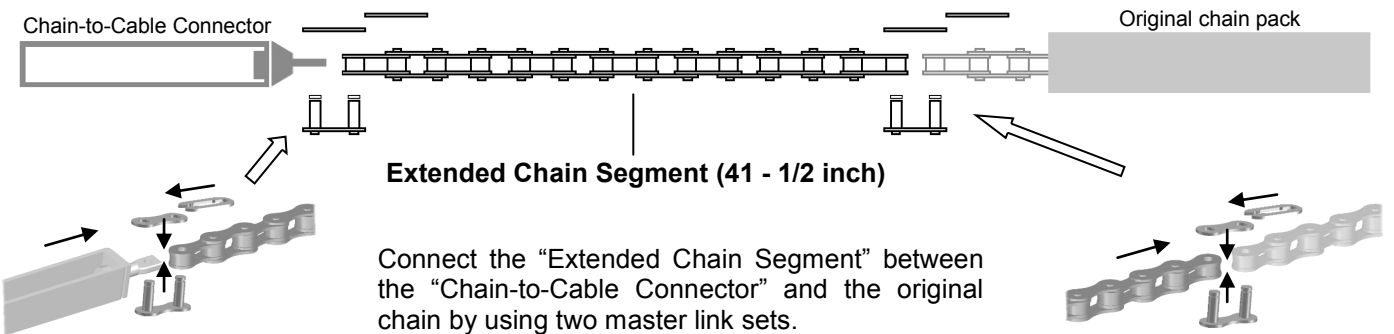

Connect the "Extended Chain Segment" between the "Chain-to-Cable Connector" and the original chain by using two master link sets.

Note: Disregard red mark on chain when adding the extension kit. The distance from the cable eyelet to the center of the sprocket must be 17-1/2 inch.

Step 3. Extending the Cable

Replace the original cable with the "Extended Cable"

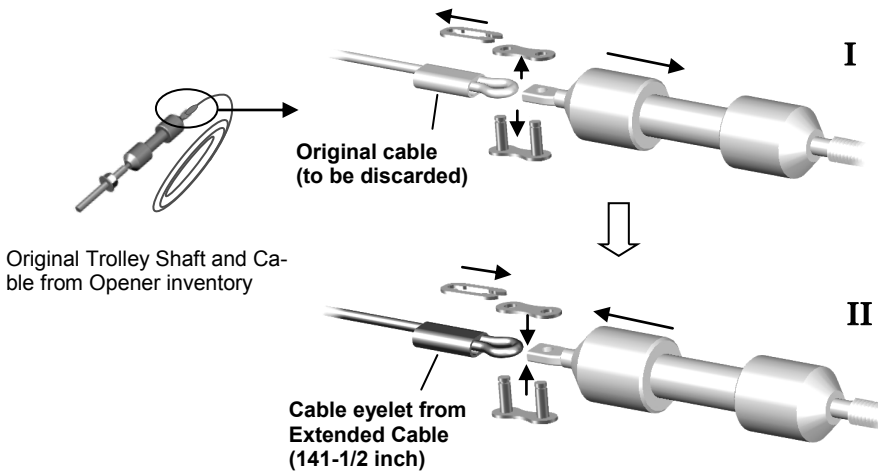

I. Disconnect the "Trolley Shaft" from the original cable by removing the master link.

Discard the original cable.

II. Align the "Trolley Shaft" to one of the eyelets of the "Extended Cable", connect them together using the master link set.

Step 4. Proceeding with Installation of Opener

The Rail Assembly Extension has now been finished.

The Rail Assembly consists of 3 pieces of extended rail segments, chain segment and cable with eyelets.

ALL 5 pieces of original rail segment and original cable are discarded.

Please proceed installation of opener starting with "Rail and Trolley Assembly" in Owner's Manual.